

Flameproof Camera Enclosure

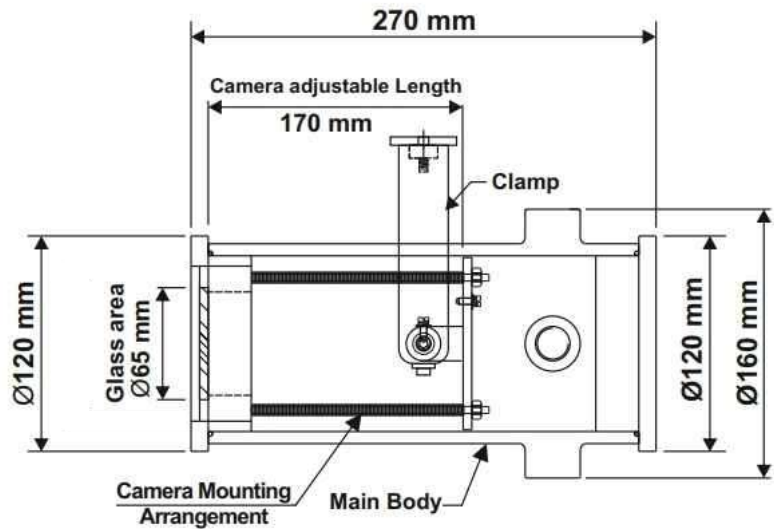
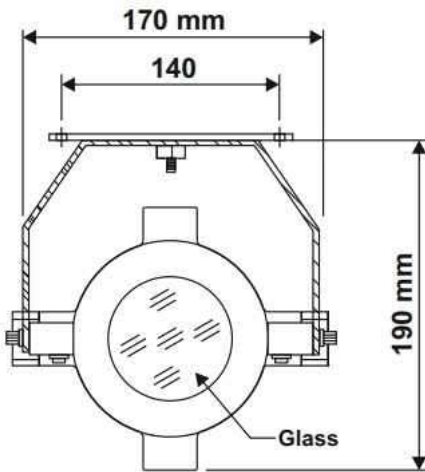

SALIENT FEATURES

	SALIENT FEATURES
Operating Temp.	Up to 55°C
Humidity	90 % at 40°C
Enclosure	LM6, Aluminum
Coating	Powder coated
Dimension	As per drawing
Weight	4.3 Kg MAX.
Cable entry	M20 or 1/2" NPT or 3/4" NPT (select any one)
Mounting	Wall mounting / slab mounting type
Gas group	IIA & IIB , Zone 1 & Zone 2
Application	Hazardous area
Weather protection	IP 65

Flameproof Instrumentation

Plot. No. E/14, Addl. MIDC, Anand Nagar, Ambarnath (E), Dist. Thane, Maharashtra, India — 421 506.,

sales@flameproof.co.in

9321160178

www.flameproof.co.in

Internal Dimension / Space Available for Camera fitment

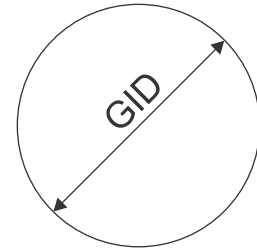
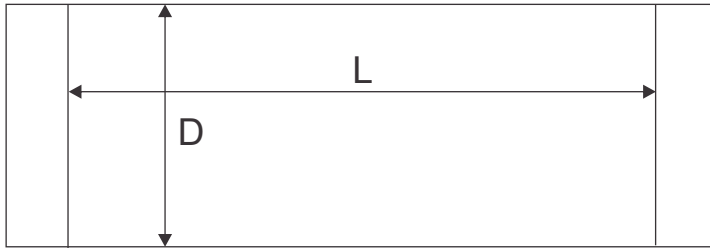

L	D	GID
170mm	90mm	65mm

L - Maximum Available Length

D - Maximum Available Diameter

GID - Maximum Glass Internal diameter

Flameproof Instrumentation

Plot. No. E/14, Addl. MIDC, Anand Nagar, Ambarnath (E), Dist. Thane, Maharashtra, India — 421 506.,

sales@flameproof.co.in

9321160178

www.flameproof.co.in